

PROGRESSING CAVITY PUMP FOR PUMPING DESTEMMED CRUSHED GRAPES

Models

- Kappa 15
- Kappa 25
- Kappa 50
- Kappa 60
- Kappa 90
- Kappa 150

Technical description

Self-priming progressing cavity pump for pumping destemmed crushed grapes.

The pumping unit consists of a stainless steel rotor and a food grade rubber stator. The rotor is composed of one principle screw with round thread that turns in the stator which is two principles female spiral. The two elements engaging mutually form some cavities representing the liquid conveyor rooms. Thanks to these features, the solid parts of the pumped product are under reduced stress.

Progressing cavity on trolley, with feeding hopper, its parts in contact with the product are made of AISI 304 stainless steel and food grade rubber. Level sensor for automatic start in the presence of product. Temperature sensor on the stator. This pump is equipped with control panel.

Features

- Electric control panel.
- Safety device stopping the pump in case of lack of product in order to not burn the stator.
- Accident prevention protection grid on the hopper.

OPTIONS	KAPPA 15	KAPPA 25	KAPPA 50	KAPPA 60	KAPPA 90	KAPPA 150
Control with variable frequency drive	•	•	•	•	standard	X
Pump on wheels	standard	standard	•	•	X	X

• available

X not available

Drawing

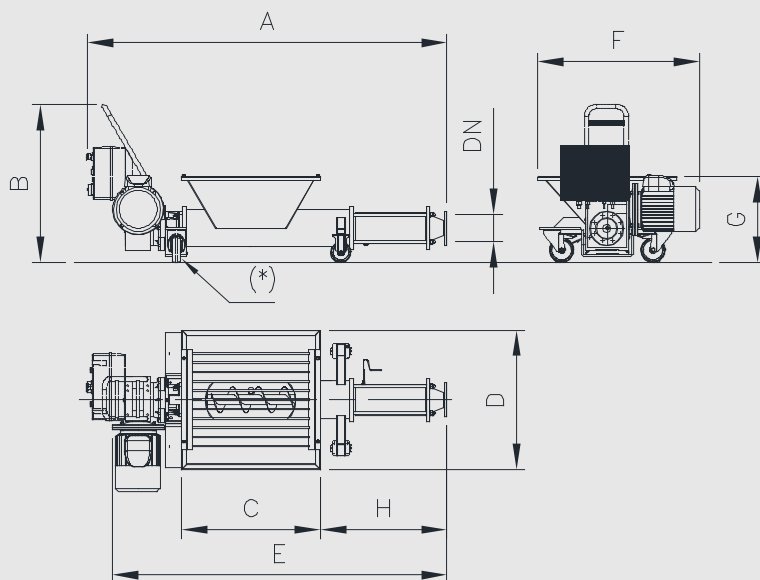

TECHNICAL DATA	KAPPA 15	KAPPA 25	KAPPA 50	KAPPA 60	KAPPA 90	KAPPA 150
A (mm)	2.008	2.158	2.743	2.785	3.654	2.934
B (mm)	922	922	613	611	690	730
C (mm)	810	810	900	900	1.200	1.250
D (mm)	810	810	900	900	1.100	1.105
E (mm)	2.008	2.158	2.743	2.785	3.654	2.940
F (mm)	940	980	900	900	1.100	1.955
G (mm)	513	513	613	611	690	730
H (mm)	736	796	874	874	1.381	990
DN	80	100	125	125	150	200
Installed power (kW/50Hz)	5,5	7,5	11	15	18,5	22
Delivery (m ³ /h)	15	25	55	60	100	140